

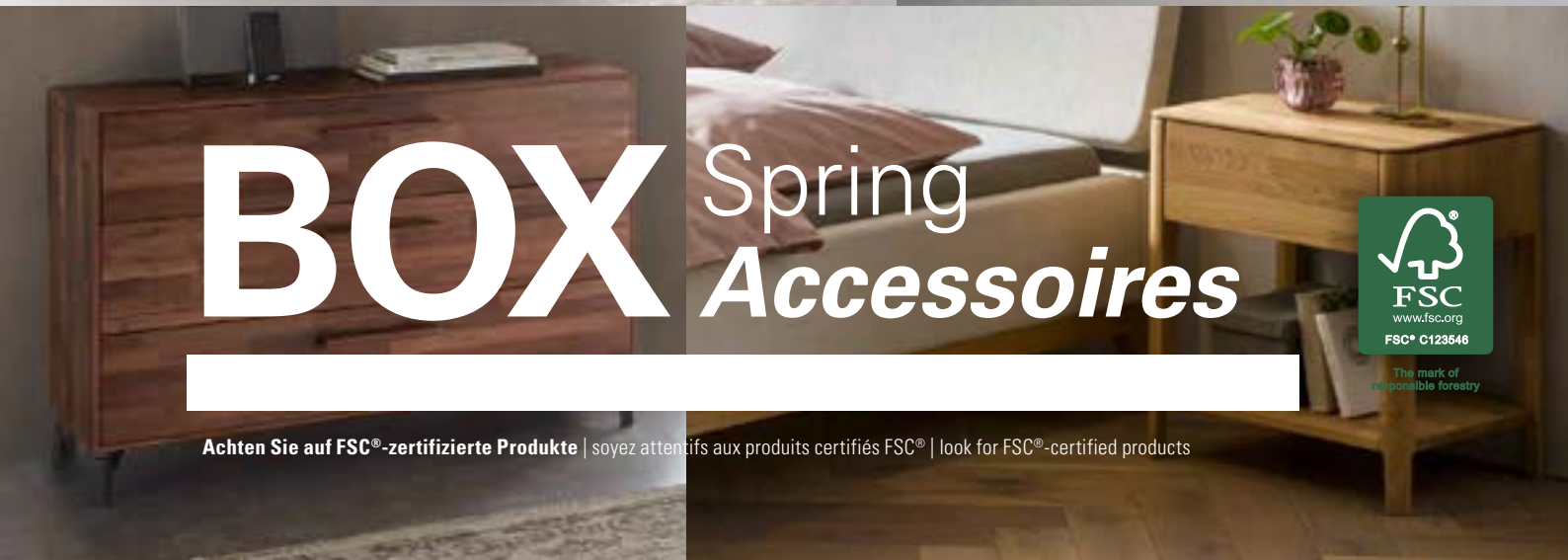

swiss bed concept















BOX Spring Accessoires



The mark of responsible forestry

Achten Sie auf FSC®-zertifizierte Produkte | soyez attentifs aux produits certifiés FSC® | look for FSC®-certified products

	Technische Details Détails techniques Technical details	Lichtquelle/-regulierung Source lumineuse/régulation lumière Light source/-regulation	Bedienung Utilisation Handling
Boa 	12V DC, 12 LED, 60 lm	LED kalt weiss / einstufig de lumière blanche froide/ interrupteur à 1 cran cold white/one level	Touch-Sensor am Lampenkopf Touche sensorielle à la tête de la lampe Touch-sensor at lamphead
Smart 	12V DC, 30 LED warm, 183 lm Dreistufenschaltung Interrupteur à 3 crans Three-step circuit	LED warm weiss / 3 Helligkeitsstufen de lumière blanche chaude / interrupteur à 3 crans warm white / 3 level	Druckknopf am Lampenkopf Bouton-poussoir à la tête de la lampe Push button at lamphead
Snake 	12V DC, 6 LED, 110 lm 3 Beleuchtungsarten 3 différent illuminations 3 different illuminations	LED 3-stufig = Lichtwahl kalt weiss, warm oder kalt/warm gemischt Interrupteur à 3 crans = choix de lumière blanche froide, chaude ou froide/chaude mélangées 3 level = choice of light cold white, warm or cold/warm mixed	Druckknopf am Lampenkopf Bouton-poussoir à la tête de la lampe Push button at lamphead
Tina 	12V DC, 1 LED, 75 lm	LED Licht neutral weiss Lumière blanc neutre Light neutral white	Druckknopf am Lampenkopf Bouton-poussoir à la tête de la lampe Push button at lamphead
LED-Light-Profil 	Sockelbeleuchtung, LED Flexiband, 10 x 10 mm Profilleuchten 12V DC, 27,9 W, 60 LED/m warm weiss Éclairage de socle, LED band flexible, 10 x 10 mm luminaires profilés 12V DC, 27,9 W, 60 LED/m blanc chaud Socket lighting, LED flexible strip, 10 x 10 mm profile luminaires 12V DC, 27,9 W, 60 LED/m warm white	LED Lichtfarbe 3200-3500K, warm weiss Couleur de lumière 3200-3500K, blanc chaud Light colour 3200-3500K, warm white	Funkschalter zum Ein-/Ausschalten und Dimmen Interrupteur sans fil pour allumer/ éteindre ou baisser Radio switch to switch on/off and to dim
für Sockelbeleuchtung von Rocc, Boca und Forma éclairage de socle pour Rocc, Boca et Forma socket lighting for Rocc, Boca and Forma	LED Transformator transformateur transformator 12V DC, 2,4 A, 30 W, 100-240 Volt		

Ausführung Exécution Execution		
Boa chrom 	Flexarm und Kopf in chrom Bras flexible et tête en chrome Flexible arm and lamphead in chrome	
Smart black 	Flexarm und Kopf in weiss oder schwarz Bras flexible et tête en blanc ou noir Flexible arm and lamphead in white or black	Smart white 
Snake alu 	Flexarm und Kopf alufarbig Bras flexible et tête en teinté alu Flexible arm and lamphead alucoloured	
Tina chrom 	Flexarm und Kopf in chrom Bras flexible et tête en chrome Flexible arm and lamphead in chrome	
Combino 		Adapter für die Lampen adaptateur pour les lampes adapter for the lamps Boa, Smart, Snake, Tina Adapter zur Befestigung der Lampen an folgenden Kopfteilen, Wandpaneelen und Betten Pronto adaptateur pour la fixation des lampes aux têtes de lit, panneaux muraux et des lits Pronto adapter to mount the lamps to the following headboards, wallpanels and Pronto beds Lille, Nizza, Palermo, Milano, Azina Colina Pronto: Bella, Costa, Denver, Finca, Fleur, Lodge, Miami, Scandia
Bei Kopfteilen Lyon und Florenz sind die Lampen nicht montierbar les lampes ne peuvent pas être montées sur les têtes de lit Lyon et Florence lamps cannot be fitted to the headboards Lyon and Florence		

Nachttische | tables de nuit | bedside tables



Nachttische | tables de nuit | bedside tables

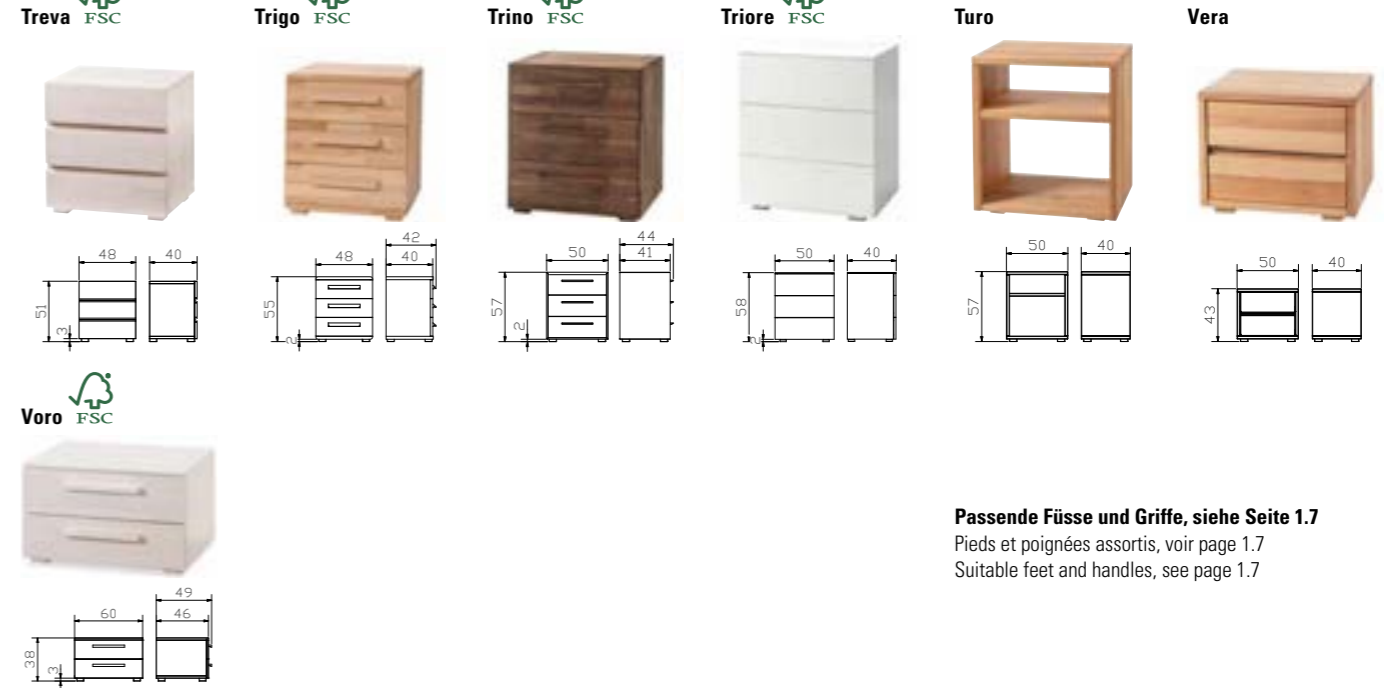

Passende Füße und Griffe, siehe Seite 1.7
Pieds et poignées assortis, voir page 1.7
Suitable feet and handles, see page 1.7

Holzfarben (Ansicht Farben siehe Seite 1.14) | couleurs bois (voir couleurs page 1.14) | wood colours (see colours page 1.14)

	06	07	08	09	10	16	30	35	49	50	55	59	61	62	64	71	73	80	81	85	86	87	89	90	91	92	93	96	98
Brig																													
Butch																													
Cali																													
Cara																													
Carpi																													
Cera																													
Cerina																													
Cervo																													
Circo																													
Cubo																													
Drema																													
Dupla																													
Esto																													
Flims																													
Koro																													
Lina																													
Lona																													
Ludo																													
Menza																													
Mino																													
Nali																													
Noma																													
Osta																													
Pero																													
Plato																													
Primea																													
Quora																													
Rio																													
Sica																													
Tercio																													
Treva																													
Trigo																													
Trino																													
Triore																													
Turo																													
Vera																													
Voro																													

Kommoden | commodes | chests of drawers

Aida

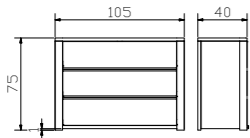

Alto FSC

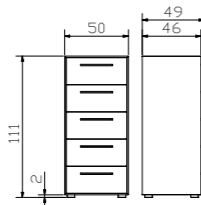

Basso

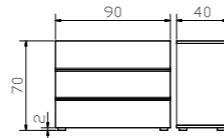

Casia + Jone FSC

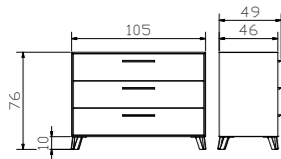

Cassetto

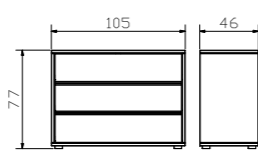

Cessa

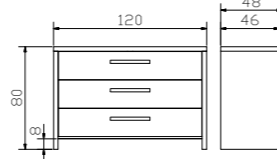

Covaro FSC

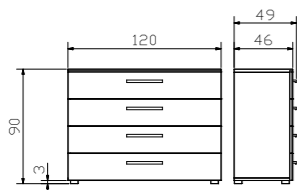

Lovara FSC

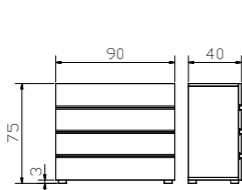

Blumotion



Für unsere Nachttische und Kommoden verwenden wir ausschliesslich den gedämpften Selbsteinzug Blumotion von BLUM.
Pour nos tables de nuit et commodes nous utilisons exclusivement les tiroirs avec système d'amortissement Blumotion de BLUM.
For our bedside tables and chests of drawers we utilize exclusively the silent and soft self closing drawer runner Blumotion of BLUM.

Kommoden | commodes | chests of drawers

Rivera FSC

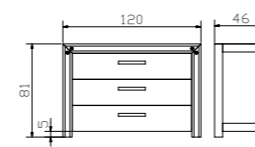

Sigma

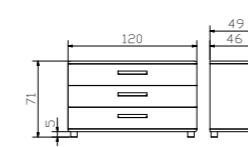

Viola FSC

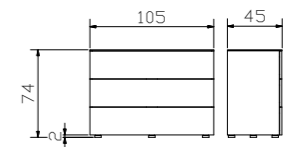

Holzfarben (Ansicht Farben siehe Seite 1.14) | couleurs bois (voir couleurs page 1.14) | wood colours (see colours page 1.14)

	06	07	08	09	10	16	30	35	49	50	55	59	61	62	64	73	80	81	85	86	87	89	90	91	92	93	96	98	
Aida																													
Alto																													
Basso																													
Casia																													
Cassetto																													
Cessa																													
Covaro																													
Lovara																													
Rivera																													
Sigma																													
Viola																													

Füsse | pieds | feet

Sima 10/20



Jone 10*
anthracit, white, used



Leg 8

alu, chrom, inox



Tindo 10*

alu, anthracit, bronze, copper



Piedo 8

alu, chrom



Cua 7



Roll 8

alu, chrom



Loa 7



Fuss Set (4 Stk.) | set de pieds (4 pces) | set of feet (4 pces)

Option zu | option pour | option to:

Nachttische | tables de nuit | bedside tables

Cerina*
Drema*
Dupla*
Menza*
Mino
Noma
Sica
Trigo
Trino
Triore
Vera
Voro*

Kommoden | commodes | chests of drawers

Alto
Basso*
Casia
Cassetto
Covaro*
Lovara*
Sigma
Viola

*nicht montierbar | montage impossible | not mountable

Griffe | poignées | handles

Covo

Alu



Chrom



Inox

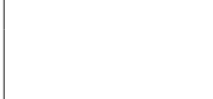

Seca

Iron



Anthracit



Rivo

Used



Anthracit



Bronze



Copper

Option zu | option pour | option to:

Nachttische | tables de nuit | bedside tables

Cera
Cerina
Cervo
Noma
Rio
Sica
Trigo
Trino
Voro

Kommoden | commodes | chests of drawers

Alto
Casia
Cessa
Covaro
Rivera
Sigma

Nachttische, Kommoden | tables de nuit, commodes | bedside tables, chests of drawers

Modo



Tola



Chest



Modo, Tola, Chest
 standardmässig mit Holzgriffen, optional Covo, Seca und Rivo Griffe
Korpus = MDF betonfarbig lackiert, Innenschubladen = Akazie massiv, grau lackiert; Fronten in allen aufgeführten Holz Ausführungen erhältlich
 standard avec poignées en bois, en option poignées Covo, Seca et Rivo
 corps = mdf teinté béton, laqué; tiroirs intérieur = acacia massif, gris lacqué, façades dans tous les exécutions en bois mentionnés disphestonible |
 with wooden handles standard, optional Covo, Seca and Rivo handles
 corpus = mdf concrete coloured, lacquered; inside drawers = solid acacia, grey lacquered, fronts in all listed wooden executions available

Füsse | pieds | feet



Fuss Set (4 Stk.) | set de pieds (4 pcs) | set of feet (4 pcs)

Griffe | poignées | handles



Nachttische, Kommoden | tables de nuit, commodes | bedside tables, chests of drawers

Duqa anthracit

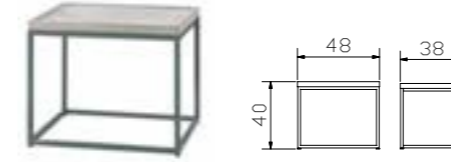

Pira

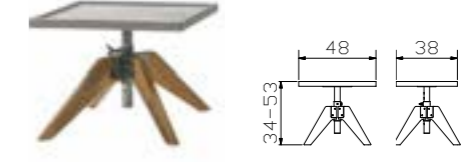

Rico 46 + 54



Tree



Beton | béton | concrete

Duqa, Pira, Rico = Auflageplatte Echtbeton | plaque d'appui béton véritable | support plate real concrete
Tree = Echtbeton, Farb- und Strukturunterschiede sind naturbedingte Eigenschaften | béton véritable, les différences de couleurs et structures sont des particularités naturelles | real concrete, differences in colour and structures are natural characteristics

20
Beton grey
 béton grey
 concrete grey

	00	04	10	16	20	40	41	42	43	45	62	64	71	73	80	85	87	90	92	93	96
Chest			•		•						•	•			•	•		•		•	
Duqa				•	•																
Modo			•		•						•	•			•	•		•		•	
Pira					•						•	•						•		•	
Rico					•								•								
Tola			•		•						•	•			•	•		•		•	
Tree					•																
Füsse pieds feet																					
Cua																					•
Jone		•	•	•																	
Leg	•							•	•												
Loa																					•
Piedo								•													
Roll								•													
Sima				•																	
Tindo					•		•	•	•					•	•	•				•	
Griffe poignées handles																					
Covo	•								•	•											
Rivo		•		•		•	•														
Seca				•						•											

Ausführungen Metall | exécutions métal | executions metal

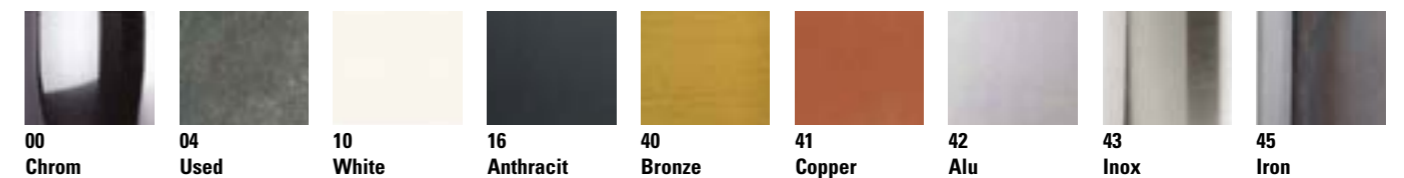

Chrom = Metall verchromt | métal chromé | metal chrome-plated
Used = Metall galvanisiert | métal galvanisé | metal galvanised
White = Metall pulverbeschichtet | métal thermolaqué | metal powder-coated
Anthracit = Metall pulverbeschichtet | métal thermolaqué | metal powder-coated
Bronze = Metall lackiert | métal laqué | metal lacquered
Copper = Metall lackiert | métal laqué | metal lacquered
Alu = Metall pulverbeschichtet | métal thermolaqué | metal powder-coated
Inox = Edelstahl gebürstet | acier inoxydable brossé | stainless steel brushed
Iron = Metall geflammt, pulverbeschichtet | métal flammé, thermolaqué | metal mottled, powder-coated

Bank + Kissen | banquette + coussin | bench + cushion

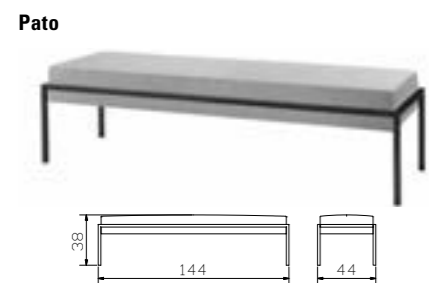
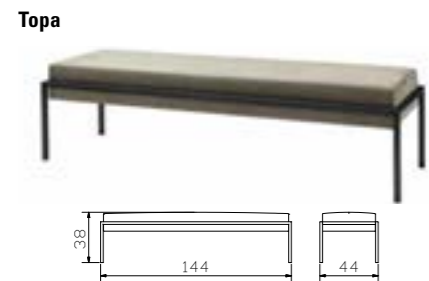
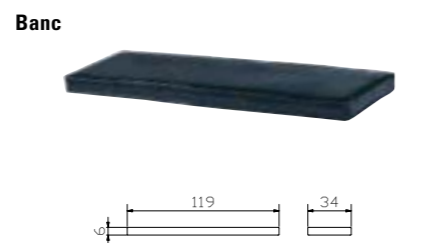
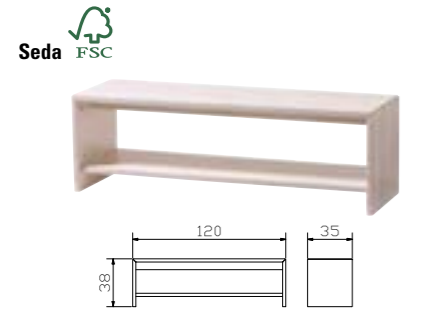
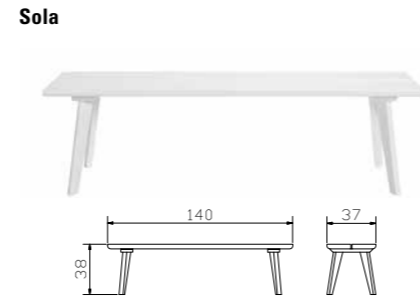
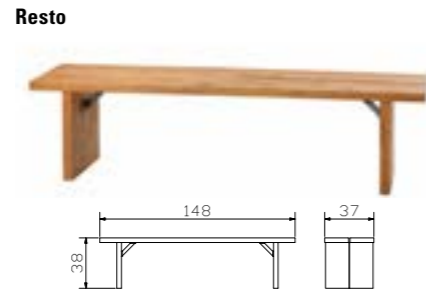
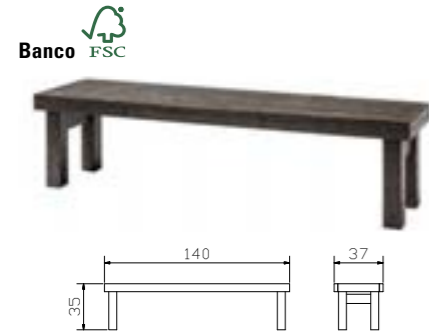

Stoffauswahl Pato (Pronto) | choix de tissus Pato (Pronto) | choice of fabrics Pato (Pronto)



Weitere Informationen siehe Register 8 | davantage informations plus détaillées voir registre 8 | other detailed information see index 8

Atrium alu, anthracit

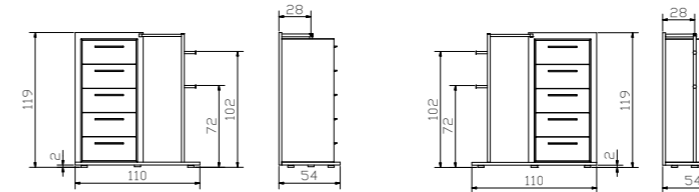

Metallstange/Rückplatte links und rechts montierbar, inklusive Holzablage Tray
barre métallique/plaque arrière peut être montée à gauche et à droite, vide poche Tray inclus
metal bar/back plate can be assembled left and right, wood tray included



Option: Tray Holzablage für Atrium + Atrio
vide poche pour Atrium + Atrio
wood tray for Atrium + Atrio

Herrendiener | valet | dressboy

Emilio alu, chrom

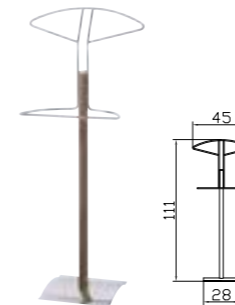

Claudio alu, anthracit, iron

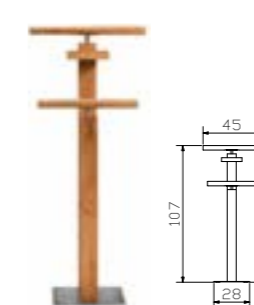

Silvio alu, anthracit, inox

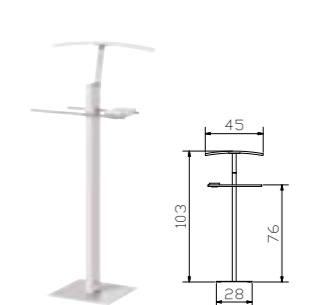

Farben (Ansicht Farben siehe Seite 1.14) | couleurs (voir couleurs page 1.14) | colours (see colours page 1.14)

	06	07	09	10	16	20	30	40	41	61	62	64	73	80	85	86	87	89	90	91	93	96	98
Atrio				•	•																		
Atrium				•	•									•	•								
Banco										•	•	•											
Calmo																						•	•
Claudio														•									
Emilio				•	•		•																
Pato					•																		
Resto																						•	•
Seda	•	•	•																				
Sola				•										•	•	•	•				•		
Silvio				•										•	•								
Topa					•			•	•														
Tray				•		•								•	•								
Vecio																						•	•

Sekretär | secrétaire | bureau

Aska

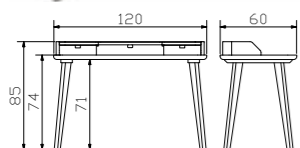

Coset

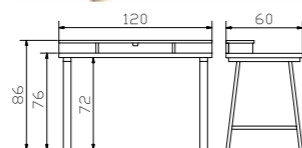

Scola

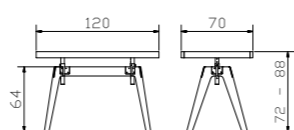

mit Schreibunterlage aus Kunstleder
Casual carbon 334
sous-main de bureau en cuir synthétique
Casual carbon 334
deskpad in synthetic leather Casual carbon 334

Schreibtisch | bureau | desk

Study

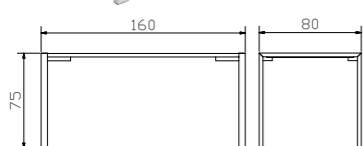

Ausführung: Tischplatte MDF mit Melamin-Folie beschichtet, Füsse aus Stahl pulverbeschichtet
Exécution : Plateau MDF mélaminé, pieds en acier thermolaqués
Execution: Tabletop in mdf laminated with melamine, feet are of steel powder-coated

Farben | couleurs | colours

	10	16	61	62	64	73	80	85	86	89	90	91	93	96	98
Aska	•					•	•	•	•	•		•			
Coset											•		•	•	•
Scola			•	•	•										
Study	•	•													

Holz | bois | wood

06 Buche natur, lackiert Hêtre naturel, laqué Natural beech, lacquered	07 Buche schoko, lackiert Hêtre teinté chocolat, laqué Beech chocolate coloured, lacquered	08 Buche kirschbaumfarbig, lackiert Hêtre teinté merisier, laqué Beech cherry coloured, lacquered	09 Buche weiss, lasiert, lackiert Hêtre teinté blanc lasuré, laqué Beech white stained, lacquered	10 Buche weiss deckend, lackiert Hêtre blanc couvrant, laqué Beech white covered, lacquered	20 Beton grey béton grey concrete grey
61 Akazie Vintage white, lackiert Acacia Vintage white, laqué Acacia Vintage white, lacquered	62 Akazie Vintage brown, lackiert Acacia Vintage brown, laqué Acacia Vintage brown, lacquered	64 Akazie Vintage grey, lackiert Acacia Vintage grey, laqué Acacia Vintage grey, lacquered	71 Eiche bianco, stabverleimt, geölt Chêne bianco, lamellé-collé, huilé Oak bianco, plywood, oiled	73 Eiche bianco, gebürstet, geölt Chêne bianco, brossé, huilé Oak bianco, brushed, oiled	80 Kernbuche natur, geölt Hêtre coeur rouge naturel, huilé Heart beech natural, oiled
81 Buche walnuss, geölt Hêtre teinté noyer, huilé Beech walnut, oiled	85 Nussbaum, geölt Noyer, huilé Walnut, oiled	86 Eiche natur, gebürstet, geölt Chêne naturel, brossé, huilé Oak natural, brushed, oiled	87 Wildbuche natur, geölt Hêtre nouveaux naturel, huilé Wildbeech natural, oiled	89 Eiche graphit, gebürstet, geölt Chêne graphit, brossé, huilé Oak graphit, brushed, oiled	90 Wildecke Vintage natur, geölt Chêne nouveaux Vintage naturel, huilé Wildoak Vintage natural, oiled
91 Eiche cognac, gebürstet, geölt Chêne cognac, brossé, huilé Oak cognac, brushed, oiled	92 Kernesche natur, lackiert Frêne coeur noir naturel, laqué Heart ash natural, lacquered	93 Wildecke natur, gebürstet, geölt Chêne nouveaux naturel, brossé, huilé Wildoak natural, brushed, oiled	96 Wildecke pure, gebürstet, geölt Chêne nouveaux pure, brossé, huilé Wildoak pure, brushed, oiled	98 Wildecke coffee, gebürstet, geölt Chêne nouveaux coffee, brossé, huilé Wildoak coffee, brushed, oiled	

Holz-Nachbildungen | bois laminé | wood laminated

10 Weiss Blanc White	16 Anthracit	30 Walnuss Noyer Walnut	35 Hochglanz weiss Blanc brillant White highgloss
49 Beton Nachbildung Beton laminé Beton laminated	50 Eiche sägerauh natur Chêne brut de sciage naturel Oak rough sawn natural	55 Esche hell Frêne clair Ash light	59 Buche Hêtre Beech

Stoff- und Kunstlederauswahl | choix de tissus et cuirs synthétiques | choice of fabrics and synthetic leathers

3. Preiskategorie | 3^e catégorie de prix | 3rd price range

Alpina 390–394, 100% Polyester



390 lightgrey 391 anthrazit 392 red 393 navy 394 smoke

Boston 650–654, Oberfläche | surface: 100% Polyester, Basis | base: 70% Polyester, 30% Baumwolle | coton | cotton



650 clay 651 bean 652 mocca 653 turtle 654 tizo

Campos 372–376, Kunstleder | cuir synthétique | synthetic leather

Oberfläche | surface: 100% Polyurethan | polyurethane, Basis | base: 71% Polyester, 29% Baumwolle | coton | cotton



372 blanc 373 creme 374 cafe 375 nero 376 kit

Casual 330–334, Kunstleder | cuir synthétique | synthetic leather

Oberfläche | surface: 100% Polyurethan | polyurethane, Basis | base: 60% Polyester, 40% Baumwolle | coton | cotton



330 sahara 331 cannelle 332 cognac 333 olive 334 carbon

Kabo 630–634, 100% Polyester



630 calc 631 rust 632 apple 633 lagoon 634 belle

Kitana 600–604, 100% Polyester



600 beige 601 nougat 602 grigio 603 aqua 604 anthrazit

Ranch 660–664, 100% Baumwolle | coton | cotton



660 stone 661 grit 662 jeans 663 indigo 664 hunter

Shine 680–685, 100% Polyester



680 wine 681 rose 682 opal 683 musk 684 curry 685 stone