



swiss bed concept



MODERNO

massiv | massif | solid



The mark of responsible forestry

Achten Sie auf FSC®-zertifizierte Produkte | soyez attentifs aux produits certifiés FSC® | look for FSC®-certified products

Bettrahmen | cadre de lit | bedframe

Trento 23 FSC



Breiten | largeurs | widths:
140, 160, 180, 200 cm

Längen | longueurs | lengths:
200, 210, 220 cm

Einlegetiefe | hauteur encastrable | insertion depth:
18*, 23 cm



* Trento 23

Bei der Einlegetiefe 18 cm sind die Füße/Sockel um 5 cm versenkt und um diese Höhe weniger sichtbar.

Avec les équerres en position haute (18 cm) les pieds/ socle sont encastrés de 5 cm sous le cadre et donc moins visibles.

With the insertion depth 18 cm the feet/socket are sunken in by 5 cm and this height less visible.

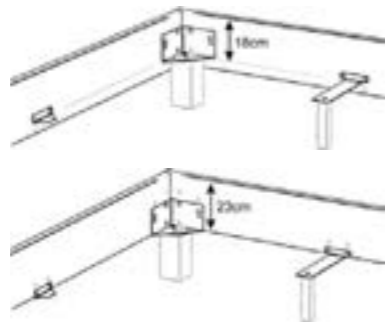

Option Midtraver-move

nicht bei Füßen in der Höhe 30 cm anwendbar
ne s'applique pas aux pieds à une hauteur de 30 cm
not applicable for feet at a height of 30 cm

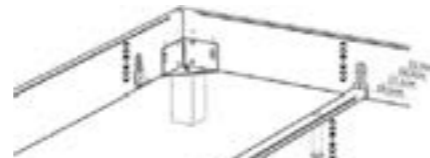

Verwendung der Kopfteile Carina + Dolce mit Midtraver-Move ist nicht möglich, siehe Seite 7.54 |

L'utilisation des têtes de lit Carina + Dolce avec Midtraver-Move n'est pas possible, voir page 7.54 |
Use of the headboards Carina + Dolce with Midtraver-Move is not possible, see page 7.54

Traversen | traverses | bars

Wir empfehlen grundsätzlich den Einsatz von Crosstraver (Quertraverse) oder Midtraver (Längstraverse).

Nous recommandons en général l'utilisation de Crosstraver (traverse transversale) ou Midtraver (traverse centrale).
We recommend basically the insertion of Crosstraver (central cross bar) or Midtraver (central bar).

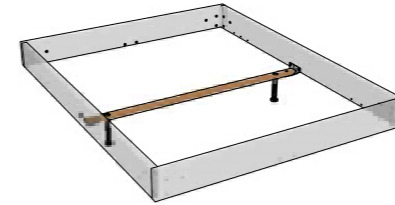

Crosstraver

Quertraverse | traverse transversale | central cross bar

Für alle Bettbreiten | pour toutes les largeurs de lit | for all bed widths

Achtung: Crosstraver ist nicht mit den Füßen Lovie-Box und Practico-Box einsetzbar

Attention : Crosstraver ne peut pas être utilisée avec les pieds Lovie-Box et Practico-Box

Attention: Crosstraver cannot be used with the Lovie-Box and Practico-Box

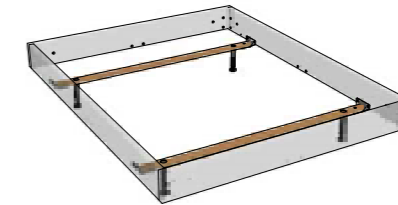

Crosstraver-Twin

Quertraversen | traverses transversales | cross bars

Für alle Bettbreiten | pour toutes les largeurs de lit | for all bed widths

Achtung: Crosstraver-Twin ist nicht mit den Füßen Evio, Vilo, Lovie-Box und Practico-Box einsetzbar

Attention : Crosstraver-Twin ne peut pas être utilisée avec les pieds Evio, Vilo, Lovie-Box et Practico-Box
Attention: Crosstraver-Twin cannot be used with legs Evio, Vilo, Lovie-Box and Practico-Box

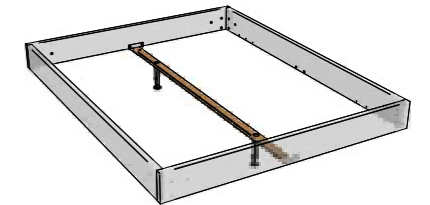

Midtraver

Längstraverse | traverse centrale | central bar

Für Betten ab Breite 160 cm mit 2 Lattenrosten oder Motorrahmeneinbau | pour les lits à partir de 160 cm de largeur avec 2 sommiers ou l'installation d'un cadre motorisé | for beds from 160 cm width with 2 slats or motor frame installation

Achtung: Midtraver ist nicht mit den Füßen Evio, Vilo, Lovie-Box und Practico-Box einsetzbar

Attention : Midtraver ne peut pas être utilisée avec les pieds Evio, Vilo, Lovie-Box et Practico-Box
Attention: Midtraver cannot be used with legs Evio, Vilo, Lovie-Box and Practico-Box

Einfach zur Ruhe kommen

Mit unseren Moderno-Modellen gelingt dies auf schlichte, stilvolle Weise. Die in der Höhe oder im Profil auffälligen Bettrahmen und die besonders feine Verarbeitung von Massivholz sorgen für Finesse und Leichtigkeit im Schlafzimmer.

Unsere Moderno-Betten sind in den folgenden Ausführungen erhältlich:

- Nussbaum natur, stabverleimt, geölt
- Buche, weiss deckend, lackiert

Calme-toi, c'est tout

Avec nos modèles Moderno, cela réussit d'une manière simple et élégante. Les cadres de lit qui frappent par leur hauteur ou leur profil et la finition particulièrement soignée du bois massif garantissent finesse et légèreté dans la chambre à coucher.

Nos lits Moderno sont disponibles dans les versions suivantes :

- noyer naturel, lamellé collé, huilé
- hêtre, laqué blanc couvrant

Just come to rest

With our Moderno models this succeeds in a simple, stylish way. The bed frames that are striking in height or profile and the particularly fine workmanship of solid wood ensure finesse and lightness in the bedroom.

Our Moderno beds are available in the following versions:

- walnut natural, glued-laminated, oiled
- beech, white covered lacquered

Ausführungen | exécutions | executions

Holz | bois | wood

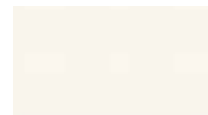

10
Buche weiss deckend, lackiert
Hêtre blanc couvrant, laqué
Beech white covered, lacquered



85
Nussbaum, geölt
Noyer, huilé
Walnut, oiled

Füsse | pieds | feet

Holz | bois | wood



Holz bois wood	Masse cm dim. cm	Breiten cm largeurs cm widths cm	Höhen cm hauteurs cm heights cm				Holzfarben couleurs bois colours wood		
			10	20	25	30	10	16	85
Cantu	8 × 8			●	●	●	●	●	●
Evio		140–200			●	●			
Ivio	10 × 10		●	●	●	●		●	
Lovie-Box** (1 Schublade/tiroir/drawer)		140			●				
Lovie-Box** (2 Schubladen/tiroirs/drawers)		140–200			●				
Masi	6 × 4			●	●			●	
Practico-Box* (inkl. Boden fond inclus bottom included)		140–200			●				
Vilo		140–200		●				●	

*weiss/anthrazit = MDF | blanc/anthracite = MDF | white/anthracite = MDF

**bei Trento 23 Rahmen nur mit Einlegetiefe 23 cm möglich | avec cadre Trento 23 uniquement possible avec la hauteur encastrable de 23 cm | with Trento 23 frame only possible with insertion depth 23 cm

Ausführungen | exécutions | executions

Holz | bois | wood



- 10 Buche weiss deckend, lackiert**
Hêtre blanc couvrant, laqué
Beech white covered, lacquered
- 16 Buche anthracit deckend, lackiert**
Hêtre anthracite couvrant, laqué
Beech anthracite covered, lacquered
- 85 Nussbaum, geölt**
Noyer, huilé
Walnut, oiled

▲ Curty Vorhang und Vela Baldachin-Tuch siehe Register 2, Seite 12

Curty rideau et Vela tissu de baldachin voir registre 2, page 12
Curty curtain and Vela canopy cloth see index 2, page 12

Füsse | pieds | feet

Metall | métal | metal



Metall métal metal	Masse cm dim. cm	Breiten cm largeurs cm widths cm	Höhen cm hauteurs cm heights cm				Metallfarben couleurs métal colours metal										
			10	20	25	30	00	04	10	16	40	41	42	43	45		
Caro	6 × 6		●	●	●		●										
Cielo [▲]		140–200		●													
Fasio	∅ 5/9			●													
Gina*	3,5 × 3,5			●													
Grado	∅ 6/10			●													
Indus	6 × 2	140–200		●	●												
Jeno	12 × 5		●	●	●												
Jump*	∅ 10/12			●													
Mico	8 × 8		●	●	●												
Quada	20 × 6,5			●	●												
Rally	∅ 10			●													
Reca	24 × 12			●													
Road**	∅ 13			●													
Slid	8/1	140–200		●	●												
Soko	∅ 6			●	●												
Stomp	∅ 8		●	●	●	●											
Tondo*	∅ 3,5			●													

*bei Trento 23 nur Einlegetiefe 23 cm möglich | pour Trento 23 uniquement avec profondeur d'insertion 23 cm | with Trento 23 only 23 cm insertion depth possible

**Füsse fixiert, Rollen nur optisch | pieds fixes, roulettes uniquement décoration | feet fixed, castors only visual

▲ Curty Vorhang und Vela Baldachin-Tuch siehe Register 2, Seite 12 | Curty rideau et Vela tissu de baldachin voir registre 2, page 12 | Curty curtain and Vela canopy cloth see index 2, page 12



- Chrom = Metall verchromt** | métal chromé | metal chrome
- Used = Metall galvanisiert** | métal galvanisé | metal galvanised
- White = Metall pulverbeschichtet** | métal thermolaqué | metal powder-coated
- Anthracit = Metall pulverbeschichtet** | métal thermolaqué | metal powder-coated
- Bronze = Metall lackiert** | métal laqué | metal lacquered
- Copper = Metall lackiert** | métal laqué | metal lacquered
- Alu = Metall pulverbeschichtet** | métal thermolaqué | metal powder-coated
- Inox = Edelstahl gebürstet** | acier inoxydable brossé | stainless steel brushed
- Iron = Metall geflammt, pulverbeschichtet** | métal flammé, thermolaqué | metal mottled, powder-coated

Bettkasten mit Holzkufe | tiroir de lit avec patins en bois | bed drawer with wooden vat

Lovie-Box + Covero 
90-140 cm 1 Schublade | 1 tiroir | 1 drawer

Stauraum | compartiment de rangement | storage space:
134 × 61 × 16 cm

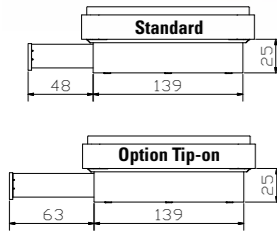

Standard: gedämpfter Selbststeinzug Blumotion von BLUM
Option: Tip-on-Öffnung mit Vollauszug von BLUM

Lovie-Box + Saceto 
140-200 cm 2 Schubladen | 2 tiroirs | 2 drawers

Stauraum | compartiment de rangement | storage space:
2 × 134 × 61 × 16 cm

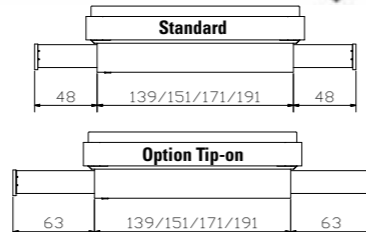

standard: système d'amortissement Blumotion de BLUM
option: ouverture Tip-on avec sortie totale de BLUM
standard: soft closing runner Blumotion of BLUM
option: opening Tip-on with full extension of BLUM

Roll-Box 20/25 



Voraussetzungen für Einsatz Bettkasten
Generell
Bettfußhöhe von mindestens 20 oder 25 cm erforderlich.
Seitlich
mit Midtraver möglich.
Optionen
Deckel Covero in weiss, Stoffabdeckung Saceto in Polyester grau.

Roll-Box 20/25 + Covero 



Conditions d'utilisation d'un tiroir de lit
En général
Une hauteur de pieds de lit d'au moins 20 cm ou 25 cm est nécessaire.
Insertion latérale
avec Midtraver possible.
Options
Couvricle Covero en blanc, tissu de protection Saceto en polyester gris.

Roll-Box 20/25 + Saceto 



Requirements for using bed drawer
General
Feet of bed need a minimum height of 20 cm or 25 cm.
Laterally
with Midtraver possible.
Options
Covero in white, tissue of protection Saceto in polyester grey.

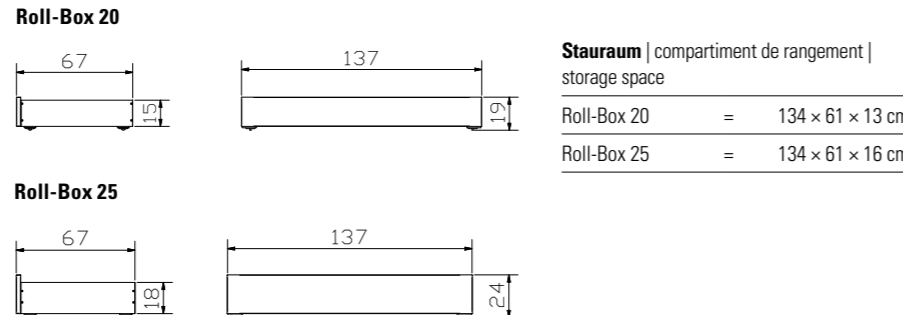

Bettkasten | coffre à literie | bedding box

Practico-Box + Trento 23 + Ultrafree-Lift KF



Ultrafree-Lift KF

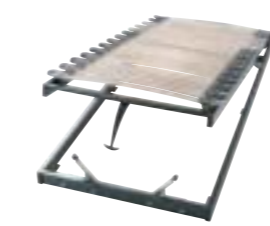

Box = inkl. Boden, Anwendung siehe Seiten 7.62/63
zu Practico-Box:
Lattenrost **Ultrafree-Lift KF**
Kopf-/Fussverstellung
Rahmenholme Höhe 7 cm und 28 Federleisten aus Buchenschichtholz
Gesamthöhe 11 cm

Lattenrost **Econom-move**
Unverstellbar
Rahmenholme Höhe 6 cm und 28 Federleisten aus Buchenschichtholz
Gesamthöhe 9 cm

inkl. Gasdruckfedern und allen Beschlägen

Details zu Ultrafree-Lift KF und Econom-move siehe Register 13, Seite 6

Practico-Box + Trento 23 + Econom-move



Econom-move

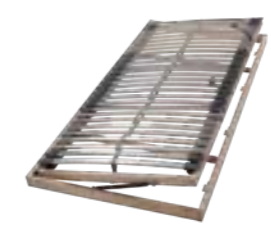

box = fond inclus, utilisation voir pages 7.62/63
pour box Practico:
Sommier **Ultrafree-Lift KF**
Tête et pied réglables
Cadre, hauteur 7 cm et 28 lattes en hêtre multiplis
Hauteur totale 11 cm

Sommier **Econom-move**
Non réglable
Cadre, hauteur 6 cm et 28 lattes en hêtre multiplis
Hauteur totale 9 cm

Pistons à gaz et toute la quincaillerie inclus

Détails pour Ultrafree-Lift KF et Econom-move voir registre 13, page 6

Stauraum | compartiment de rangement | storage space

140 × 200/210/220	=	131 × 190/200/210 × 24 cm
160 × 200/210/220	=	74 × 190/200/210 × 24 (2 x) cm
180 × 200/210/220	=	84 × 190/200/210 × 24 (2 x) cm
200 × 200/210/220	=	94 × 190/200/210 × 24 (2 x) cm

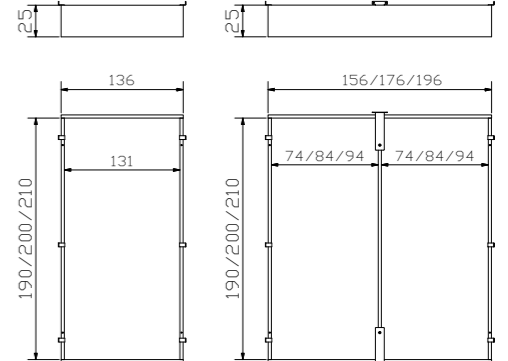

box = bottom incl., handling see pages 7.62/63
for Practico-box:
Slats **Ultrafree-Lift KF**
Head/footpiece adjustable
Frame, height 7 cm and 28 slats are of beech veneer board
Total height 11 cm

Slats **Econom-move**
Not adjustable
Frame, height 6 cm and 28 slats are of beech veneer board
Total height 9 cm

Pneumatic compression spring and all fittings included

Details for Ultrafree-Lift KF and Econom-move see index 13, pages 6

Himmelbett ohne Grenzen | lit à baldachin sans frontières | canopy bed without borders

Bettahmen | cadre de lit | bedframe
Cielo-Ron | Baldachin | baldaqin | canopy
Kopfteil | tête de lit | headboard

Kopfteile | têtes de lit | headboards



Dimension 140, 160, 180, 200



Dimension: 140, 160, 180, 200

gepolstert | rembourrées | upholstered

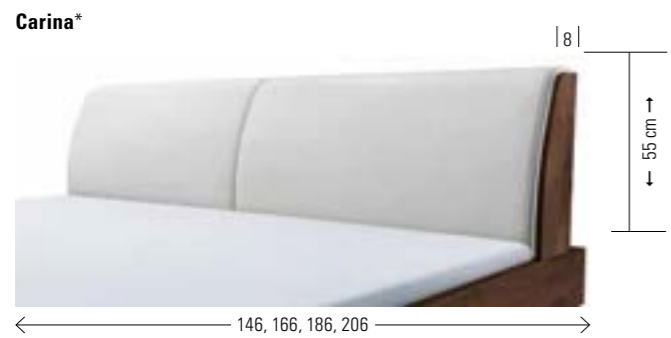

Dimension: 140, 160, 180, 200



Dimension: 140, 160, 180, 200

Ausführungen | exécutions | executions

Holz | bois | wood

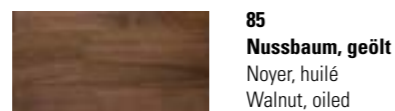
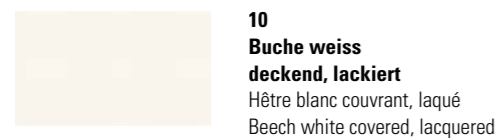

Dimension: 140, 160, 180, 200



Dimension: 140, 160, 180, 200

Gewünschte Liegefläche (Länge) = zu bestellende Bettrahmenlänge
surface de couchage souhaitée (longueur) = longueur de cadre de lit à commander
desired mattress lying area (length) = length of bedframe to be ordered

190 = 200
200 = 210
210 = 220

***Verwendung dieser Kopfteile mit Midtraver-Move ist nicht möglich |**
L'utilisation de ces têtes de lit avec Midtraver-Move n'est pas possible |
Use of these headboards with Midtraver-Move is not possible

Kissen zu Kopfteilen | coussins pour têtes de lit | cushions for headboards



Befestigung mit 2 Bändern (Klettverschluss)

Fixation avec 2 bandes (Velcro®)
Fixation with 2 ribbons (Velcro® fastener)

Stoffauswahl/Farben für Kissen siehe Register 1, Seiten 6–7

Choix de tissus/couleurs pour coussins voir registre 1, pages 6–7
Choice of tissues/colours for cushions see index 1, pages 6–7

Kissen coussins cushions	Effektive Masse cm dimension effective cm effective dimension cm	zu Kopfteilen pour têtes de lit for headboards		Breitenmasse cm dimensions de largeur cm widths dimensions cm
		Duetto	Varus	
Arona	136, 156, 176×3,5×25	●		140, 160, 180/200
Lumo	136, 156, 176×6×25	●		140, 160, 180/200
Ravo	130, 150, 170, 190×3,5×35	●	●	140, 160, 180, 200
Suny*	55×6×40	●	●	
Varo*	55×10×35	●	●	

*2er Set | set de 2 | set of 2

Adapter | adaptateur | adapter

Bei hohen Matratzen kann mit dem Verlängerungsadapter das Kopfteil um 9 oder 13 cm erhöht werden.

La tête de lit peut être rehaussée de 9 ou 13 cm avec l'adaptateur quand le matelas est plus épais.
With the extension adapter the headboard can be extended 9 or 13 cm if mattresses are high.

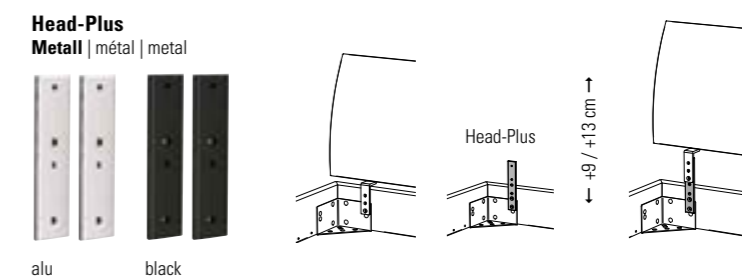

Nachttische, Kommoden | tables de nuit, commodes | bedside tables, chests of drawers

Circo 44/52

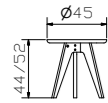

Caja FSC



für Montage am Bett
pour montage au lit
for assembling directly to the bed

Sica FSC

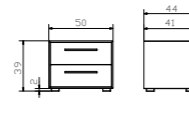

Trino + Jone FSC

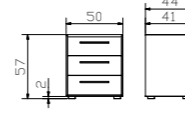

Modo FSC

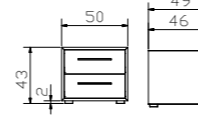

Alto FSC

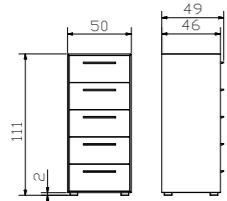

Casia FSC

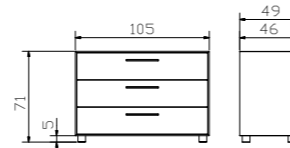

Tola FSC

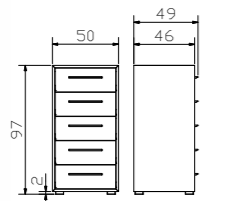

Chest FSC

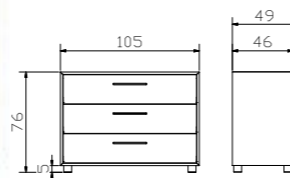

Blumotion



Für unsere Nachttische und Kommoden verwenden wir ausschliesslich den gedämpften Selbsteinzug Blumotion von BLUM.

Pour nos tables de nuit et commodes nous utilisons exclusivement les tiroirs avec système d'amortissement Blumotion de BLUM.

For our bedside tables and chests of drawers we utilize exclusively the silent and soft self closing drawer runner Blumotion of BLUM.

Füsse | pieds | feet = Option zu | pour | for Alto, Sica, Trino, Modo, Casia, Tola, Chest

Sima 10+20 FSC



Leg 8 alu, chrom, inox



Jone 10 anthracit, used, white



Piedo 8 alu, chrom



Tindo 10 alu, anthracit, bronze, copper



Roll 8 alu, chrom



Griffe zu | poignées pour | handles for Alto, Atrium, Sica, Trino, Modo, Casia, Tola, Chest

Covo



Alu



Chrom



Inox

Rivo



Used

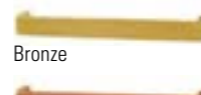

Anthracit

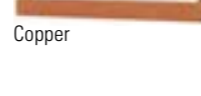

Bronze



Copper

Fuss Set (4 Stk.)

set de pieds (4 pcs) | set of feet (4 pcs)

7.56

Fuss Set (4 Stk.)

set de pieds (4 pcs) | set of feet (4 pcs)

7.56

Fuss Set (4 Stk.)

set de pieds (4 pcs) | set of feet (4 pcs)

7.56

Beimöbel | accessoires | accessories

Bank + Kissen | banquette + coussin | bench + cushion

Sola FSC

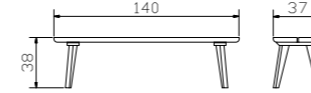

Vano

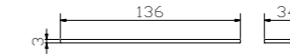

Topia

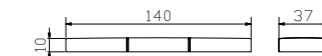

Vano, Topia

Bezugsstoffe siehe Register 1, Seiten 8 – 9 | Tissus de revêtement voir registre 1, pages 8 – 9 | Cover fabrics see index 1, pages 8 – 9

Atrium alu, anthracit FSC

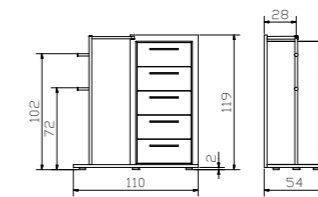
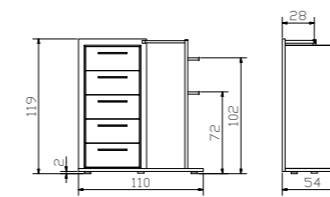

Silvio alu, anthracit, inox FSC

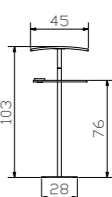

Metalstange/Rückplatte links und rechts montierbar inklusive Holzablage Tray
barre métallique/plaque arrière peut être montée à gauche et à droite, vide poche Tray inclus
metal bar/back plate can be assembled left and right, wood tray included

Ausführungen | exécutions | executions

Holz | bois | wood

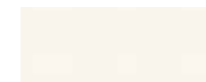

10 Buche weiss deckend, lackiert

Hêtre blanc couvrant, laqué
Beech white covered, lacquered



85 Nussbaum, geölt

Noyer, huilé
Walnut, oiled

Sekretär | secrétaire | bureau

Aska FSC

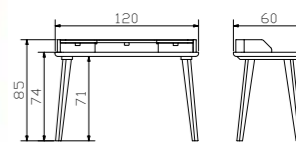

Metall | métal | metal



00 Chrom



04 Used

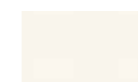

10 White



16 Anthracit



40 Bronze



41 Copper



42 Alu



43 Inox



45 Iron



				Dimension cm
Aska	Sekretär	secrétaire	bureau	120/60/85
Tree	Nachttisch/Hocker	table de nuit/tabouret	bedside table/stool	Ø 42/44
Circo 52	Nachttisch/Hocker	table de nuit/tabouret	bedside table/stool	Ø 45/52
Alto Sima 10	Kommode Füße	commode pieds	chest of drawers feet	50/49/119
Curty	Baldachin-Vorhang (3er Set) Baumwolle weiss	rideau de baldaquin (set de 3) coton blanc	curtain of canopy (set of 3) cotton white	272/185 (3x)

				Dimension cm
Trento 23	Rahmen Breiten Längen	cadre largeurs longueurs	frame widths lengths	140, 160, 180, 200 200, 210, 220
Cielo white	Baldachin Breiten Längen Höhen	baldaquin largeurs longueurs hauteurs	canopy widths lengths heights	140, 160, 180, 200 200, 210, 220 20
Vola	Kopfteil	tête de lit	headboard	140, 160, 180, 200



Curty

Alle Holzteile in Buche weiss deckend, lackiert | toutes les parties en bois en hêtre blanc, couvrant, laqué | all wooden parts in beech white covered, lacquered

Tree in Echtbeton | Tree en béton véritable | Tree in real concrete

Weitere Beimöbel siehe Register 2 | autres accessoires voir registre 2 | further accessories see index 2

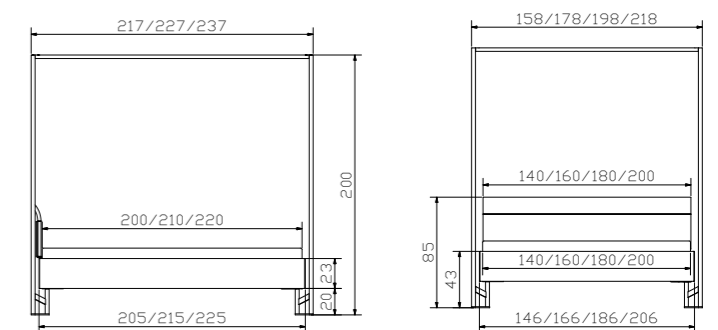



				Dimension cm
Trino	Nachttisch	table de nuit	bedside table	50/44/57
Atrium anthracit	Garderobenmöbel	meuble de penderie	wardrobe furniture	110/54/119
Smart white	Lampen (2er Set), weiss 12V DC, 30 LED warm	lamps (set de 2), blanc 12V DC, 30 LED warm	lamps (set of 2), white 12V DC, 30 LED warm	

				Dimension cm
Trento 23	Rahmen Breiten Längen	cadre largeurs longueurs	frame widths lengths	140, 160, 180, 200 190 (200), 200 (210), 210 (220)
Slid white	Kufen Breiten Höhen	patins largeurs hauteurs	vats widths heights	140, 160, 180, 200 20, 25
Dolce	Kopfteil, Campos blanc 372 hat Einfluss auf Bettlänge siehe Seite 7.54	tête de lit, Campos blanc 372 a un impact sur la longueur du lit voir page 7.54	headboard, Campos blanc 372 affects the length of bed see page 7.54	140, 160, 180, 200

Alle Holzteile in Buche weiss deckend, lackiert | toutes les parties en bois en hêtre blanc couvrant, laqué | all wooden parts in beech white covered, lacquered
Lampen und weitere Beimöbel siehe Register 2 | lampes et autres accessoires voir registre 2 | lamps and further accessories see index 2

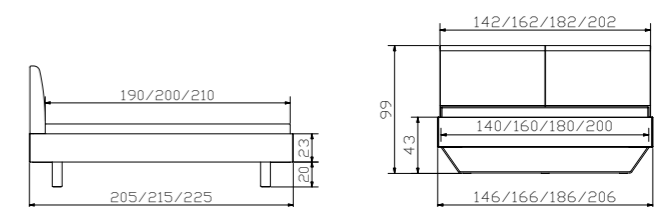



				Dimension cm
Sola	Bank	banquette	bench	140/37/38
Vano	Kissen, Shine stone 685	coussin, Shine stone 685	cushion, Shine stone 685	136/34/3
Casia	Kommode	commode	chest of drawers	105/49/76
Jone 10 white	Füsse	pieds	feet	
Sica	Nachttisch	table de nuit	bedside table	50/44/47
Jone 10 white	Füsse	pieds	feet	



Details siehe Seite 7.53
 Détails voir page 7.53
 Details see page 7.53

				Dimension cm
Trento 23	Rahmen Breiten Längen	cadre largeurs longueurs	frame widths lengths	140, 160, 180, 200 200, 210, 220
Practico-Box white	Breiten Längen Höhen	largeurs longueurs hauteurs	widths lengths heights	140, 160, 180, 200 200, 210, 220 25
Duetto	Kopfteil	tête de lit	headboard	140, 160, 180, 200
Arona	Kissen, Shine stone 685	coussin, Shine stone 685	cushion, Shine stone 685	140, 160, 180/200

Alle Holzteile in Buche weiss deckend, lackiert |
 toutes les parties en bois en hêtre blanc, couvrant, laqué |
 all wooden parts in beech white covered, lacquered

Weitere Beimöbel siehe Register 2 | autres accessoires
 voir registre 2 | further accessories see index 2

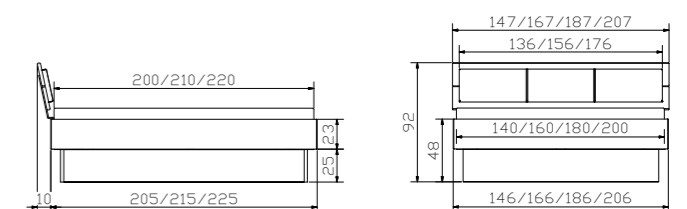



				Dimension cm
Alto	Kommode	commode	chest of drawers	50/49/111
Trino	Nachttisch	table de nuit	bedside table	50/44/57
Silvio alu	Herrendiener	valet	dressboy	45/28/103

				Dimension cm
Trento 23	Rahmen Breiten Längen	cadre largeurs longueurs	frame widths lengths	140, 160, 180, 200 200, 210, 220
Ivio	Füße Höhen	pieds hauteurs	feet heights	10, 20, 25, 30
Malta	Kopfteil, Alpina smoke 394 siehe Register 1	tête de lit, Alpina smoke 394 voir registre 1	headboard, Alpina smoke 394 see index 1	140, 160, 180, 200

Alle Holzteile in Buche weiss deckend, lackiert | toutes les parties en bois en hêtre blanc, couvrant, laqué | all wooden parts in beech white covered, lacquered
Lampen und weitere Beimöbel siehe Register 2 | lampes et autres accessoires voir registre 2 | lamps and further accessories see index 2

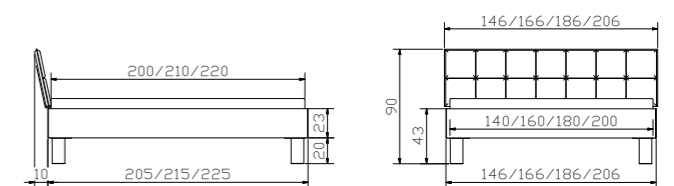



			Dimension cm
Lovie-Box	1 Bettkasten	1 tiroir de lit	1 bed drawer
	Breiten	largeurs	widths
	2 Bettkästen	2 tiroirs de lit	2 bed drawers
	Breiten	largeurs	widths
	Höhe	hauteur	height
			140
			140, 160, 180, 200
			25

				Dimension cm
Trento 23	Rahmen	cadre	frame	
	Breiten	largeurs	widths	140, 160, 180, 200
	Längen	longueurs	lengths	200, 210, 220
Lovie-Box anthracit	Breiten	largeurs	widths	140, 160, 180, 200
	Höhen	hauteurs	heights	25
Vola	Kopfteil	tête de lit	headboard	140, 160, 180, 200
Aska	Sekretär	secrétaire	bureau	120/60/85
Circo 44	Nachttisch/Hocker	table de nuit/tabouret	bedside table/stool	Ø 45/44
Sica	Nachttisch	table de nuit	bedside table	50/44/47
Sima 10	Füsse	pieds	feet	

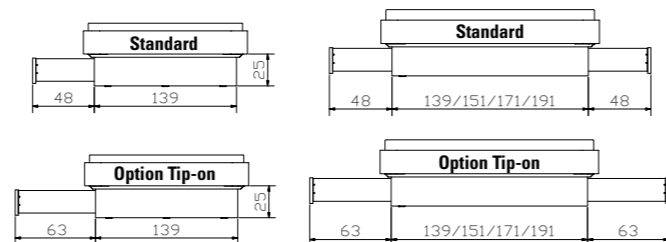

Alle Holzteile in Nussbaum, geölt |
 toutes les parties en bois en noyer, huilé |
 all wooden parts in walnut, oiled
Lampen und weitere Beimöbel siehe Register 2 |
 lampes et autres accessoires voir registre 2 | lamps and
 further accessories see index 2

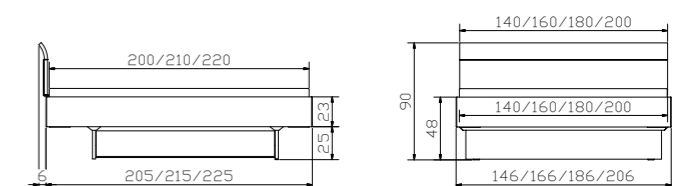



				Dimension cm
Chest	Kommode	commode	chest of drawers	105/49/76
Modo	Nachttisch	table de nuit	bedside table	50/49/43
Tola	Kommode	commode	chest of drawers	50/49/97

				Dimension cm
Trento 23	Rahmen Breiten Längen	cadre largeurs longueurs	frame widths lengths	140, 160, 180, 200 190 (200), 200 (210), 210 (220)
Slid anthracit	Kufen Breiten Höhe	patins largeurs hauteur	vats widths height	140, 160, 180, 200 20, 25
Carina	Kopfteil, Ranch grit 661 hat Einfluss auf Bettlänge siehe Seite 7.54	tête de lit, Ranch grit 661 a un impact sur la longueur du lit voir page 7.54	headboard, Ranch grit 661 affects the length of bed see page 7.54	140, 160, 180, 200

Alle Holzteile in Nussbaum, geölt | toutes les parties en bois en noyer, huilé | all wooden parts in walnut, oiled
Korpus Chest, Modo + Tola MDF betonfarbig lackiert | corps Chest, Modo + Tola en mdf teinté béton | corpus Chest, Modo + Tola in mdf concrete coloured, lacquered

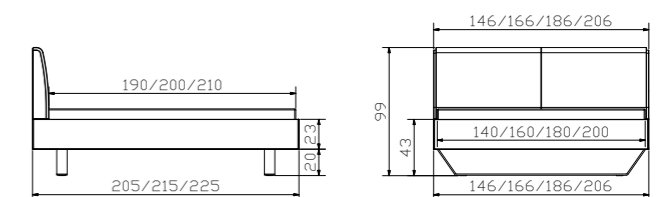



				Dimension cm
Casia	Kommode	commode	chest of drawers	105/49/76
Sima 10	Füße	pieds	feet	
Sica	Nachttisch	table de nuit	bedside table	50/44/47
Sima 10	Füße	pieds	feet	

				Dimension cm
Trento 23	Rahmen Breiten Längen	cadre largeurs longueurs	frame widths lengths	140, 160, 180, 200 200, 210, 220
Masi	Füße Höhen	pieds hauteurs	feet heights	20, 25
Ripo	Kopfteil, Kitana grigio 602 siehe Register 1	tête de lit, Kitana grigio 602 voir registre 1	headboard, Kitana grigio 602 see index 1	140, 160, 180, 200

Alle Holzteile in Nussbaum, geölt | toutes les parties en bois en noyer, huilé | all wooden parts in walnut, oiled
Lampen und weitere Beimöbel siehe Register 2 | lampes et autres accessoires voir registre 2 | lamps and further accessories see index 2

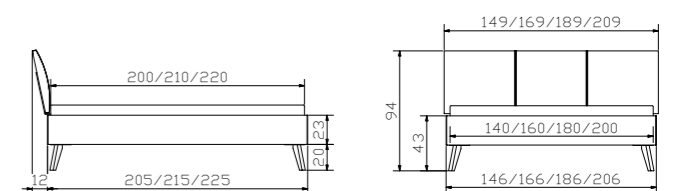



				Dimension cm
Alto	Kommode	commode	chest of drawers	50/49/111
Silvio anthracit	Herrendiener	valet	dressboy	45/28/103
Caja	Nachttisch	table de nuit	bedside table	48/41/16

				Dimension cm
Trento 23	Rahmen Breiten Längen	cadre largeurs longueurs	frame widths lengths	140, 160, 180, 200 190 (200), 200 (210), 210 (220)
Indus anthracit	Kufen Breiten Höhen	patins largeurs hauteurs	vats widths heights	140, 160, 180, 200 20, 25
Cena	Kopfteil, Kabo calc 630	tête de lit, Kabo calc 630	headboard, Kabo calc 630	140, 160, 180, 200
	hat Einfluss auf Bettlänge siehe Seite 7.54	a un impact sur la longueur du lit voir page 7.54	affects the length of bed see page 7.54	

Alle Holzteile in Nussbaum, geölt | toutes les parties en bois en noyer, huilé | all wooden parts in walnut, oiled
Lampen und weitere Beimöbel siehe Register 2 | lampes et autres accessoires voir registre 2 | lamps and further accessories see index 2

